



## ST5491E 2-WIRE SEISMIC VIBRATION TRANSMITTER

### Installation Manual



### OVERVIEW

The Model ST5491E Seismic Vibration Transmitter is the latest version of an established series of transmitters from Metrix. The ST5491E is the indicating version of Metrix Model ST5484E and comes with an integral 2-1/2 digit LCD indicator for local vibration readout. It incorporates state-of-the-art electronic components and circuits. It also offers several new options in terms of features and configurations.

The transmitter combines a vibration sensor and signal conditioner in a single package. They provide the ideal solution for sensing machinery vibration level and transmitting a proportional 4-20 mA signal directly to a PLC, DCS, monitor, or computer. Typical applications include low- and medium-speed machines such as fans, blowers, pumps, motors, and centrifuges. The transmitter can be supplied with optional screw cover elbow fittings for connecting flexible conduit.

The transmitter is all solid state, has no moving parts, and is encapsulated in a stainless steel housing. The LCD indicator is packaged in a sealed module that can be positioned in 90° increments with the elbow fitting to allow proper viewing when the transmitter is installed. Each transmitter is factory calibrated to the sensitivity marked on the label.

# INSTALLATION

## 1. MOUNTING

The transmitter body must be solidly mounted to the machine surface. See the section Typical Transducer Placement. Different machine preparations are required for the two basic transmitter mounting styles; NPT (National Pipe Thread) and machine thread (UNF and Metric). Transmitters with the NPT type mounting stud are secured by the thread engagement and the base of the transmitter does not come in contact with the machine surface. On the other hand, transmitters with the machine thread studs must make contact with the machine surface. The transmitter base must make square and direct contact. This requires preparing the surface of the machine with a 1 1/2 inch counter bore (surfacing tool). This tool can be used with a portable drill equipped with a magnetic base take care such that the tapped and threaded hole is perpendicular to the machined surface. The transmitter must make contact all the way around its base surface. Contact Metrix for more detailed instructions for using a counter bore.

If installing a transmitter with a standard 1/4 inch NPT stud, drill a hole using a 7/16 inch bit, 5/8 inch deep. Then tap using a 1/4 - 18 NPT (tapered pipe tap). Hand tighten the transmitter and then turn an additional 1 to 2 turns using a wrench on the wrench flats. **Do not use a pipe wrench.** A pipe wrench can apply extreme forces to the body and potentially damage electronic components. A minimum of five threads of engagement should be made. A 1/4 inch to 1/2 inch NPT bushing is available for mounting the transmitter in existing 1/2 inch NPT holes. Also, a Metrix Model 7084 Flange Adapter can be used between the transmitter and the machine surface when there is not enough surface thickness to drill and tap a hole. The flange adaptor mounts with three small screws. See Accessories.

If installing a transmitter with one of the straight machined thread sizes, follow standard drill and tap procedures. Be sure to not drill a hole larger than the counter bore pilot diameter before using the counter bore to prepare the machine surface. Drill out the hole with the correct tap drill size after preparing the surface.

The sensitive axis of the transmitter is in line with the mounting stud. The transmitter can be oriented in any (0 to 360 degree) position.

## 2. WIRING

The ST5491E is connected like any other loop powered transmitter. The following is a summary based on area designations.

### 2.A SAFE AREA INSTALLATION

Connect the field wiring in accordance with the appropriate diagram on page 3. The ST5491E transmitter requires a minimum of 13 VDC for proper operation. The minimum loop power supply voltage required is 13 VDC plus 1 volt for each 50 ohms of loop resistance.

ST5491E Example:	Signal wire resistance	= 10 $\Omega$
	Resistance of receiver	= 250 $\Omega$
	Total loop resistance	= 260 $\Omega$

$$\text{Minimum supply voltage} = 260 \Omega (1 \text{ VDC}/50 \Omega) + 13 \text{ VDC} = 18.2 \text{ VDC}$$

The maximum loop power supply voltage that may be applied is 30 VDC. The maximum loop resistance (RL) is calculated by the equation:

$$R_L = 50 (V_S - 13) \Omega$$

Example:  $R_L = 50 (24 - 13) = 550 \Omega$  for 24 VDC loop supply.

## 2.B EXPLOSION-PROOF INSTALLATION IN HAZARDOUS LOCATIONS

ST5491E transmitters are CSA certified explosion-proof, Class I (C & D); Class II (E, F & G,). Connect the field wiring in accordance with the appropriate diagram on page 3. Refer to paragraph 2.A for loop voltage and resistance requirements. All conduit and junction boxes used must be certified explosion-proof for the class, division and group required by the application. Installation of the transmitter must meet all of the explosion-proof installation requirements of the local governing agency and facility safety procedures.

## 3. ELECTROMAGNETIC COMPATIBILITY

To meet the requirements of electromagnetic compatibility in areas of high electromagnetic interference, the field wiring must be:

1. Shielded twisted pair cable enclosed in grounded metallic conduit, or
2. Double shielded twisted pair cable with a metallic body cable gland fitting and with the outer shield grounded.

## WIRING DIAGRAMS

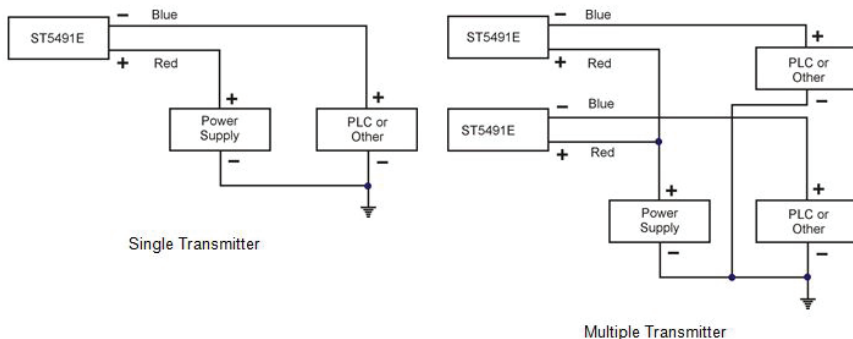

Use standard two-conductor, twisted pair, shielded wiring for the long run to the instrumentation enclosure. The transmitter is connected like any other loop powered end device.

### 3.A CONNECTION TO PLC OR OTHER INDICATING INSTRUMENT

The first step in configuring the PLC, DCS, or other recording instrument is to determine the source of power. The ST5491E requires loop power be supplied to it. Some Analog Input channels, on a PLC or DCS, for example, provide this power from within. If they do not provide power, an external power supply must be provided. Connect the transmitter field wiring using standard instrumentation practices.

Scaling of the display is on the basis of the range of the transmitter. The measurement parameter name is “vibration” and the units are “ips” (inches per second) or “mm/s” (millimeters per second). The example below is based on a standard 1.0 ips transmitter.

Vibration Level	Transmitter Output	PLC (or other) Scale
None	4mA +/-0.1mA	0.00 in/s
1.0 in/s	20mA +/-0.4mA	1.00 in/s

To prevent nuisance alarms, due to transient operating conditions, program an alarm time delay. Momentary “jolts” that can occur at start-up or during some operating condition changes, do not reflect a machines steady state operating condition. The indicated vibration level must cross the threshold level and stay above it for a preset time before any alarm action is taken. A 2- to 3-second delay is normally applied to most machinery. Consult Metrix if you have a question about your machines operating characteristics.

Some rough starting machinery may also need a start-up time lockout for alarms. A start-up lockout is different than a time delay. Both may be needed.

## **TYPICAL TRANSMITTER PLACEMENT**

The ST5491E measures seismic vibration at the attachment point on the machine. Its sensitive direction is through its cylindrical body. It will not measure side to side motion. It measures velocity vibration in ips (inches per second). Velocity vibration is a common measurement for a large variety of machinery.

Figure 1 shows a typical transmitter mounting for casing vibration measurements is in the horizontal direction at the bearing housings. Usually the horizontal direction is more sensitive because of the way machinery is typically mounted. Figure 2 shows the flying leads being spliced in the conduit elbow. Please be aware the splice can not be made at this point if in a hazardous area. In this case, make the splice in a second conduit hub (meeting splicing requirements) at the end of the flexible conduit.

The standard lead length is 24 inches. We recommend using the “Y” conduit elbow because it prevents the conduit from extending too far away from the transmitter, limiting the likelihood of getting snagged while working near the machinery. If a 1 inch to 3/4 inch reducer is used at the elbow, a smaller diameter flexible conduit can be used. It is always a good idea to limit the mass that “hangs” on the transmitter. The flexible conduit should make a bend in order to be sure any rigid conduit motion can not feed into the transmitter body.

## TYPICAL APPLICATION AND MOUNTING ARRANGEMENT

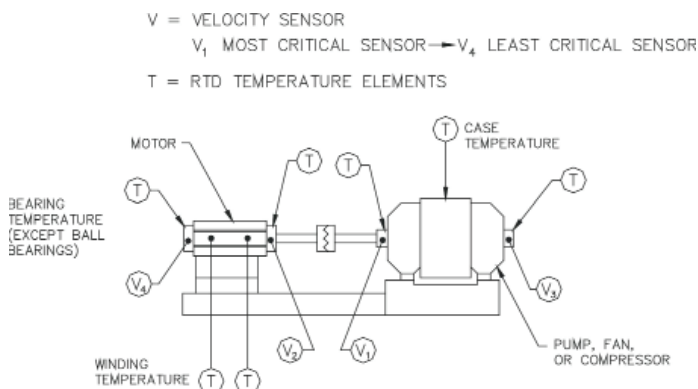

Figure 1: Horizontal mounting for casing vibration measurements.

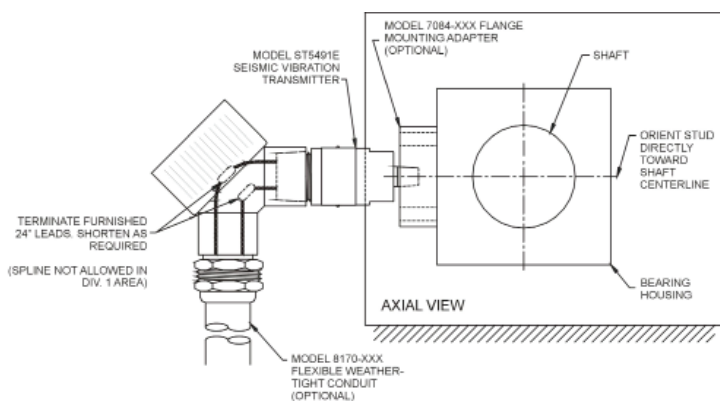

Figure 2: Flying leads spliced in conduit elbow.

## CALIBRATION

The ST5491E transmitter has been factory calibrated for the full scale vibration level marked on the label. If the calibration is in doubt the unit can be verified in the field by following the procedures outlined below. Note that there are no Zero and Span adjustments on the transmitter.

**1. Zero Verification** In the absence of vibration the output current should be 4 mA  $\pm$ 0.1 mA. If the ambient vibration is more than 2% of full scale, the transmitter should be removed from the machine and placed on a vibration free surface for this measurement. Often a piece of foam can be used to isolate the transmitter from external motion.

**2. Span Verification** Subject the transmitter to a known vibration within the full scale range marked on the label. If using a portable vibration shaker where it can be tested at full scale, the output should be 20 mA  $\pm$ 0.4 mA. If using another reference, like a similar machine, calculate the current value on a proportional basis.

The output level can also be compared to a vibration level read on a portable vibration meter. This reading should be taken as close to the transmitter location as possible.

If you shake the transmitter by hand you can produce a high output as long as there are no high pass filters. Check the configuration for filters. There is no way of knowing the expected output when shaking it by hand.

**3. Digital Indicator** Calibration of the Digital Indicator requires partial disassembly of the ST5491E. Remove the Digital Indicator threaded cover. Carefully remove the electronics module using a small flat head screwdriver. Note how the transmitter wires are connected before disconnecting them. Remove the retaining wire from the bottom of the module and carefully remove the electronics board assembly from the module housing. Connect the electronics module in series with a current loop that can be accurately set from 4.0 mA to 20.0 mA  $\pm$  0.1 mA.



**NOTE:** If a voltage source is used to generate a current, a load resistance must be connected in series with the ST5491E indicator module. Failure to do so may damage the unit.

Set the current loop to the zero current reading of the transmitter and adjust the ZERO (R7) control for a reading of 0.00. Next set the current loop to the full scale current value and adjust the SPAN (R6) control for the proper indication. Alternately adjust the ZERO and SPAN controls as adjustments interact.

Label Full Scale	Reading
1.0 in/s	1.00
19.9 mm/s	19.9
100 mm/s	100

After calibration, reassemble the module, reconnect the wiring, and reassemble the unit.

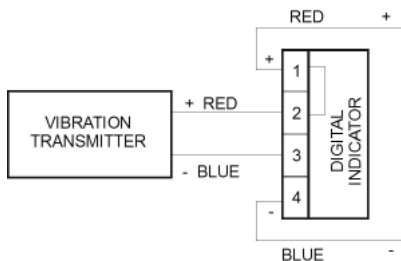

## OPTIONAL ACCESSORIES

The ST5491E is available with different mounting options. The performance of the transmitter does not change (except for the dynamic output option, discussed).

### MOUNTING



#### **8201-001, Conduit Union**

Fits between transmitter and 8200-001 conduit elbow to facilitate installation and wiring where there is not enough room to rotate the elbow. Suitable for Class I, Div. 1 (Grps A, B, C & D) and Class II, Div. 1 (Grps E, F & G), hazardous areas. Material: zinc plated steel.



#### **7084-001, Stainless Steel Flange Mount Adaptor**

Provides a means to surface mount transmitters rather than NPT stud ( $\frac{1}{2}$ " NPT center hole). Three equally spaced 6.6 mm (0.26") diameter mounting holes on 38 mm (1.50") diameter circle.

#### **7084-002, Flange Mount Adaptor**

Same as 7084-001, except center hole is  $\frac{1}{4}$ " NPT. Material: stainless steel



#### **8253-002, Bushing**

Bushing for  $\frac{1}{2}$ " NPT mount when screwed onto standard  $\frac{1}{4}$ " NPT base. Material: stainless steel.

### CONNECTION



#### **8169-75-002-XXX, Two-wire, Cable Assembly**

2 conductor (20 AWG) twisted, shielded PVC jacketed cable, with plated steel grip for cable strain relief, male  $\frac{3}{4}$ " NPT end. Specify -XXX for length in feet. Example: 8169-75-002-010 =10 ft (3.1M). Material: zinc plated steel.



#### **93818-004, Cable Grip Strain Relief Fitting**

$\frac{3}{4}$ " NPT male thread to cable grip. Diameter range: .156" to .25". Complete with sealing ring, locknut and hot dip / mechanically galvanized finish. Suitable for NEMA 4 enclosures.



#### **93818-018, Armored Cable Grip Strain Relief Fitting**

$\frac{3}{4}$ " NPT male thread to cable grip. Armor diameter range: .40" to .50". Complete with sealing ring, locknut and a hot dip / mechanically galvanized finish. Suitable for NEMA 4 enclosures.

## **ENVIRONMENTAL INFORMATION**



This electronic equipment was manufactured according to high quality standards to ensure safe and reliable operation when used as intended. Due to its nature, this equipment may contain small quantities of substances known to be hazardous to the environment or to human health if released into the environment. For this reason, Waste Electrical and Electronic Equipment (commonly known as WEEE) should never be disposed of in the public waste stream. The “Crossed-Out Waste Bin” label affixed to this product is a reminder to dispose of this product in accordance with local WEEE regulations. If you have questions about the disposal process, please contact Metrix Customer Services.

[info@metrixvibration.com](mailto:info@metrixvibration.com)

[www.metrixvibration.com](http://www.metrixvibration.com)

8824 Fallbrook Dr. Houston, TX 77064, USA

Tel: 1.281.940.1802 • Fax: 1.713.559.9421

After Hours (CST) Technical Assistance: 1.713.452.9703