



## 6850-001 Impact Meter

### Installation Manual



**6850 connected  
to an IT6810**

### OVERVIEW

The 6850 Impact Meter is designed for quick check out or adjustment of Metrix Impact transmitters, either on an operating machine, or with the transmitter removed.

Simply connect the Meter to an Impact transmitter, toggle the Power switch, and select Pulse-Time, 4-20mA, or Peak Detect mode. In Pulse-Time mode, the transmitter's Threshold level (milli-volts), and Sample Time (seconds) are displayed, and may be adjusted while observing the changes. Switching to 4-20mA mode displays the current output directly, while Peak Detect mode displays the peak vibration level, in milli-volts, detected by the transmitter.

The Peak Detect mode is provided for measuring and displaying the amplitude of Impact peaks present at the measurement location. Peak Detect mode is most useful when "fine tuning" a transmitter for a particular machine. An Impact Threshold Level 2X to 3X the base line PD level has proven to provide good machinery protection monitoring. While the Pulse Time is a function of machine operating speed, calculated as follows:  $960 \text{ divided by machine RPM} = \text{the Pulse Time (in seconds)}$ .

## **FEATURES**

- Display peak amplitude of Impacts within machine
- Display transmitter's Impact "Threshold level"
- Display transmitter's Impact "Pulse Time"
- Display transmitter's 4-20mA output
- Waveform access through BNC connector
- Powers 6810 or 6812 during setup & checkout
- Select transmitter's Pulse-Time, 4-20mA, or Peak Detect mode
- Battery powered, digital display

## **BENEFITS**

- One device for transmitter checkout & setup
- Eliminates need for oscilloscope & voltmeters
- Simple to operate for task efficiency

## **6850 OPERATION / OPERATING MODES**

The 6850 Impact Meter is designed for quick check out or adjustment of Metrix Impact transmitters, either on an operating machine, or with the transmitter removed.

Simply connect the Meter to an Impact transmitter, toggle the Power switch, and select Pulse-Time, 4-20mA, or Peak Detect mode. In Pulse-Time mode, the transmitter's Threshold level (millivolts), and Sample Time (seconds) are displayed, and may be adjusted while observing the changes. Switching to 4-20mA mode displays the current output directly, while Peak Detect mode displays the peak vibration level, in milli-volts, detected by the transmitter.

The Peak Detect mode is provided for measuring and displaying the amplitude of Impact peaks present at the measurement location. Peak Detect mode is most useful when "fine tuning" a transmitter for a particular machine. An Impact Threshold Level 2X to 3X the base line PD level has proven to provide good machinery protection monitoring. While the Pulse Time is a function of machine operating speed, calculated as follows:  $960 \text{ divided by machine RPM} = \text{Pulse Time (seconds)}$ .

## USING THE IMPACT METER

The Impact Meter is capable of taking Threshold, Pulse Time, Loop Current, and Peak Detect measurements. Prior to taking measurements with the Impact Meter, you must connect the Impact Meter to your Impact Transmitter device as shown in Figure 1.



Figure 1

### Threshold/Pulse Time Measurement

To initialize the Threshold/Pulse-Time measurement mode, set input switch 2 to Threshold, Pulse-Time, Peak Detect and input switch 3 to T/PT as shown in Figure 2.

**NOTE:** During initial power on of the Impact Meter, it may be necessary to wait up to 10 seconds for the Threshold and Pulse-Time measurements to stabilize.

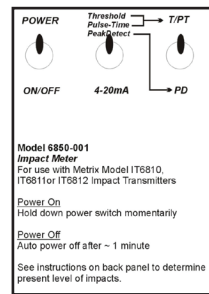
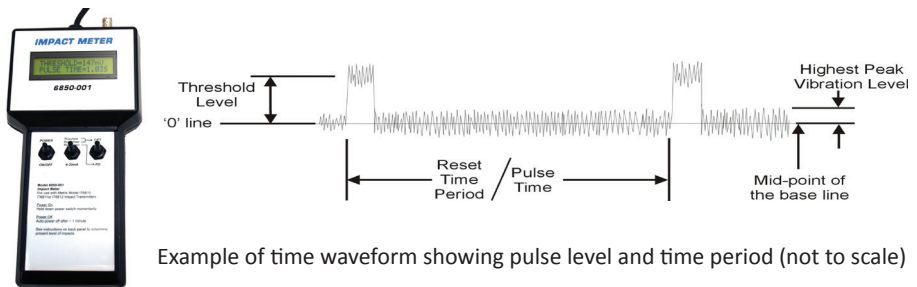

Figure 2

The Threshold/Pulse-Time measurement will configure the impact transmitter in setup mode. This mode will allow the Impact Meter to measure the Threshold and Pulse-Time generated by the Impact Transmitter. The Impact Meter will display the measured Threshold in milli-volts and the Pulse Time in seconds as shown below in Figure 3. Refer to section 5.3 and 5.4 of the IT6810/IT6811/IT6812 Impact Transmitter Manual for more information on how to set the threshold and pulse-time of the Impact Transmitter.



Example of time waveform showing pulse level and time period (not to scale)

Figure 3

## Peak Detect Measurement

To initialize the Peak Detect measurement mode, set input switch 2 to Threshold, Pulse-Time, Peak Detect and input switch 3 to PD as shown in Figure 2. If the Impact Meter is already turned on, it will automatically detect the new switch setting and proceed with the Peak Detect measurement. If the Impact Meter is turned off, momentarily toggle switch 1 to the ON/OFF position. This will initialize the Impact Meter to start making Peak Detect measurements.

During initialization of the peak detect measurement; the Impact Meter will display “Initializing Peak Detect” as shown in figure 4. The Impact Meter measures the pulse time period setting of the Impact Transmitter and uses this to determine the internal timing of the measurement.



**NOTE:** Since the peak detect measurement is reliant on a stable pulse time setting of the Impact Transmitter, it is important not to adjust the pulse time on the Impact Transmitter while taking a peak detect measurement.

The Peak Detect mode enables the Impact Meter to measure the Peak impact voltage levels generated by the Impact Transmitter. Refer to Figure 5 for an example of a typical measurement.

The peak detect measurement displays the peak voltage, Figure 6, amplitude (Impact Level) that is present during one pulse time period. The displayed value will increase if the last value measured is higher than the previous value measured. The displayed value will decrease if the new peak value is less than 1/2 of the previous peak value. For



Figure 4

Threshold Level	350mV			
	Pulse Time Period			
	t1	t2	t3	t4
1	200mV	360mV	200mV	160mV
2	320mV	260mV	320mV	100mV
3	260mV	360mV	200mV	180mV
4	300mV	300mV	320mV	80mV
5	100mV	380mV	200mV	160mV
6	260mV	320mV	320mV	60mV
7	300mV	400mV	200mV	180mV
Peak Detect Output	320mV	400mV	400mV	180mV

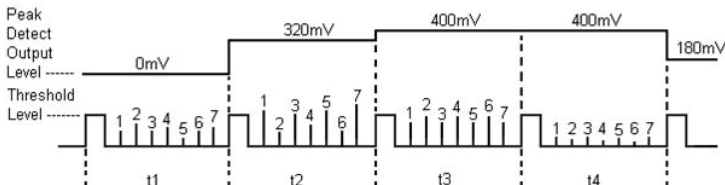

Figure 5

example, the displayed peak detect measurement for t1 as shown in Figure 8 is 320mV. This is the maximum impact level detected during the pulse time t1. During t2, the maximum impact level detected is 400mV. Since this value is greater than 320mV, the impact meter will display the new value of 400mV. During t3, the maximum impact level detected is again 320mV. However, the impact meter will continue to display 400mV since the previous value is slightly larger but not smaller by half. During t4, the maximum impact level detected is 180mV. Since this value is smaller than ½ of 400mV or smaller than 200mV, the Impact Meter will now display 180mV.

The main advantage of the peak detect measurement is that it provides a stable maximum peak “impact level” that may be used to set the Threshold level. As a rule of thumb, it is recommended that the threshold level be set 2 to 3 times the peak level during normal operation.

#### 4-20mA Measurement

To initialize the 4-20mA measurement mode, set input switch 2 to 4-20mA as shown below in Figure 2. If the Impact Meter is already turned on, it will automatically detect the new switch setting and proceed with the 4-20mA measurement. If the Impact Meter is turned off, momentarily toggle switch 1 to the ON/OFF position. This will initialize the Impact Meter to start making a 4-20mA measurement.

The 4-20mA measurement will configure the impact transmitter in normal mode. This mode will allow the Impact Meter to measure the 4 to 20mA loop current generated by the Impact Transmitter. Refer to Figure 8 for an example of a typical 4-20mA measurement. Refer to section 6 of this user manual for more information on the 4 to 20mA impact severity measurement.

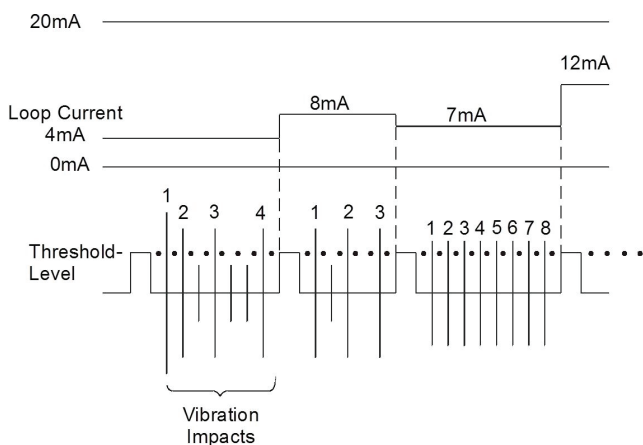

Example of current output vs. number of impacts per time period.

Impacts	mA
0	4
1	5
2	6
3	7
4	8
5	9
6	10
7	11
8	12
9	13
10	14
11	15
12	16
13	17
14	18
15	19
16	20

Figure 6

## Dynamic Signal

A BNC Connector is provided on the Impact Meter for viewing the impact waveform through the use of a scope or other measurement device.

## Battery Replacement

The Impact Meter is designed to offer approximately 8 hours of continuous operation under normal conditions. The Impact Meter checks for low batteries during power up. During this time, the Impact Meter will display “Low Battery Voltage Detected, Replace Batteries” as shown below in Figure 7 if the battery power is too low. After receiving this message, the batteries should be replaced to avoid any potential measurement errors.

To replace the batteries on the Impact Meter, remove the 6 screws on the back of the case as shown in Figure 8. This will allow access to the battery compartment.

## Shut Down

To preserve battery life, the Impact Meter will shut down power on its own. This time may vary between 5- and 15-minutes depending on which mode it is operating in.

Alternatively, the power to the device may be turned off by holding down switch 1 in the ON/OFF position for 5 seconds and then releasing it.

The Impact Meter will also automatically detect when an Impact Transmitter is not connected and will shut down on its own to preserve battery life.



Figure 7

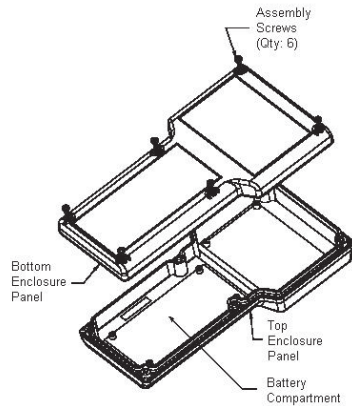
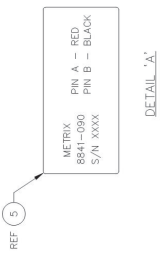
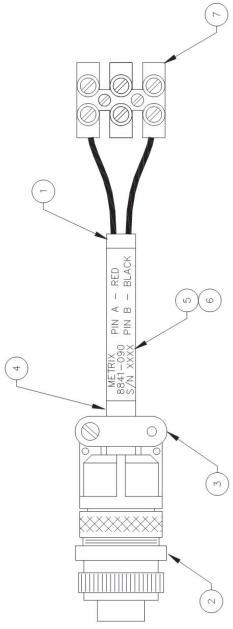

Figure 8

- NOTES: (UNLESS OTHERWISE SPECIFIED)
1. CUT CABLE (ITEM 1) TO APPROX. 6 INCHES LONG.
  2. STRIP AND TIN BOTH ENDS OF CABLE.
  3. SOLDER RED WIRE TO PIN A, BLACK WIRE TO PIN B. SECURE CONNECTOR ASSY (ITEM 2) WITH CLAMP (ITEM 3) AND BUSHING (ITEM 4).
  4. PRINT MODEL NO. AND SERIAL NO. ON LABEL (ITEM 5) AS SHOWN IN DETAIL "A".
  5. SECURE LABEL TO CABLE (ITEM 1) NEAR CONNECTOR AND COVER WITH CLEAR TUBING (ITEM 6).
  6. SECURE OTHER END OF CABLE TO TERMINAL BLOCK (ITEM 7).



MATERIAL		QUANTITY		UNIT		DESCRIPTION	
FINISH		FRAC.		DEC.		MATERIAL	
UNLESS OTHERWISE SPECIFIED, ALL DIMENSIONS ARE TO BE HONED TO ±0.0005 UNLESS OTHERWISE SPECIFIED.		FRACTIONS: DECIMALS		FRACTIONS: DECIMALS		FRACTIONS: DECIMALS	
		31/64		XXX ± 0.00		XXX ± 0.00	
		A1:		XXX ± 0.00		XXX ± 0.00	
		A2:		XXX ± 0.00		XXX ± 0.00	
		A3:		XXX ± 0.00		XXX ± 0.00	
		A4:		XXX ± 0.00		XXX ± 0.00	
		A5:		XXX ± 0.00		XXX ± 0.00	
		A6:		XXX ± 0.00		XXX ± 0.00	
		A7:		XXX ± 0.00		XXX ± 0.00	
		A8:		XXX ± 0.00		XXX ± 0.00	
		A9:		XXX ± 0.00		XXX ± 0.00	
		A10:		XXX ± 0.00		XXX ± 0.00	
		A11:		XXX ± 0.00		XXX ± 0.00	
		A12:		XXX ± 0.00		XXX ± 0.00	
		A13:		XXX ± 0.00		XXX ± 0.00	
		A14:		XXX ± 0.00		XXX ± 0.00	
		A15:		XXX ± 0.00		XXX ± 0.00	
		A16:		XXX ± 0.00		XXX ± 0.00	
		A17:		XXX ± 0.00		XXX ± 0.00	
		A18:		XXX ± 0.00		XXX ± 0.00	
		A19:		XXX ± 0.00		XXX ± 0.00	
		A20:		XXX ± 0.00		XXX ± 0.00	
		A21:		XXX ± 0.00		XXX ± 0.00	
		A22:		XXX ± 0.00		XXX ± 0.00	
		A23:		XXX ± 0.00		XXX ± 0.00	
		A24:		XXX ± 0.00		XXX ± 0.00	
		A25:		XXX ± 0.00		XXX ± 0.00	
		A26:		XXX ± 0.00		XXX ± 0.00	
		A27:		XXX ± 0.00		XXX ± 0.00	
		A28:		XXX ± 0.00		XXX ± 0.00	
		A29:		XXX ± 0.00		XXX ± 0.00	
		A30:		XXX ± 0.00		XXX ± 0.00	
		A31:		XXX ± 0.00		XXX ± 0.00	
		A32:		XXX ± 0.00		XXX ± 0.00	
		A33:		XXX ± 0.00		XXX ± 0.00	
		A34:		XXX ± 0.00		XXX ± 0.00	
		A35:		XXX ± 0.00		XXX ± 0.00	
		A36:		XXX ± 0.00		XXX ± 0.00	
		A37:		XXX ± 0.00		XXX ± 0.00	
		A38:		XXX ± 0.00		XXX ± 0.00	
		A39:		XXX ± 0.00		XXX ± 0.00	
		A40:		XXX ± 0.00		XXX ± 0.00	
		A41:		XXX ± 0.00		XXX ± 0.00	
		A42:		XXX ± 0.00		XXX ± 0.00	
		A43:		XXX ± 0.00		XXX ± 0.00	
		A44:		XXX ± 0.00		XXX ± 0.00	
		A45:		XXX ± 0.00		XXX ± 0.00	
		A46:		XXX ± 0.00		XXX ± 0.00	
		A47:		XXX ± 0.00		XXX ± 0.00	
		A48:		XXX ± 0.00		XXX ± 0.00	
		A49:		XXX ± 0.00		XXX ± 0.00	
		A50:		XXX ± 0.00		XXX ± 0.00	
		A51:		XXX ± 0.00		XXX ± 0.00	
		A52:		XXX ± 0.00		XXX ± 0.00	
		A53:		XXX ± 0.00		XXX ± 0.00	
		A54:		XXX ± 0.00		XXX ± 0.00	
		A55:		XXX ± 0.00		XXX ± 0.00	
		A56:		XXX ± 0.00		XXX ± 0.00	
		A57:		XXX ± 0.00		XXX ± 0.00	
		A58:		XXX ± 0.00		XXX ± 0.00	
		A59:		XXX ± 0.00		XXX ± 0.00	
		A60:		XXX ± 0.00		XXX ± 0.00	
		A61:		XXX ± 0.00		XXX ± 0.00	
		A62:		XXX ± 0.00		XXX ± 0.00	
		A63:		XXX ± 0.00		XXX ± 0.00	
		A64:		XXX ± 0.00		XXX ± 0.00	
		A65:		XXX ± 0.00		XXX ± 0.00	
		A66:		XXX ± 0.00		XXX ± 0.00	
		A67:		XXX ± 0.00		XXX ± 0.00	
		A68:		XXX ± 0.00		XXX ± 0.00	
		A69:		XXX ± 0.00		XXX ± 0.00	
		A70:		XXX ± 0.00		XXX ± 0.00	
		A71:		XXX ± 0.00		XXX ± 0.00	
		A72:		XXX ± 0.00		XXX ± 0.00	
		A73:		XXX ± 0.00		XXX ± 0.00	
		A74:		XXX ± 0.00		XXX ± 0.00	
		A75:		XXX ± 0.00		XXX ± 0.00	
		A76:		XXX ± 0.00		XXX ± 0.00	
		A77:		XXX ± 0.00		XXX ± 0.00	
		A78:		XXX ± 0.00		XXX ± 0.00	
		A79:		XXX ± 0.00		XXX ± 0.00	
		A80:		XXX ± 0.00		XXX ± 0.00	
		A81:		XXX ± 0.00		XXX ± 0.00	
		A82:		XXX ± 0.00		XXX ± 0.00	
		A83:		XXX ± 0.00		XXX ± 0.00	
		A84:		XXX ± 0.00		XXX ± 0.00	
		A85:		XXX ± 0.00		XXX ± 0.00	
		A86:		XXX ± 0.00		XXX ± 0.00	
		A87:		XXX ± 0.00		XXX ± 0.00	
		A88:		XXX ± 0.00		XXX ± 0.00	
		A89:		XXX ± 0.00		XXX ± 0.00	
		A90:		XXX ± 0.00		XXX ± 0.00	
		A91:		XXX ± 0.00		XXX ± 0.00	
		A92:		XXX ± 0.00		XXX ± 0.00	
		A93:		XXX ± 0.00		XXX ± 0.00	
		A94:		XXX ± 0.00		XXX ± 0.00	
		A95:		XXX ± 0.00		XXX ± 0.00	
		A96:		XXX ± 0.00		XXX ± 0.00	
		A97:		XXX ± 0.00		XXX ± 0.00	
		A98:		XXX ± 0.00		XXX ± 0.00	
		A99:		XXX ± 0.00		XXX ± 0.00	
		A100:		XXX ± 0.00		XXX ± 0.00	
		A101:		XXX ± 0.00		XXX ± 0.00	
		A102:		XXX ± 0.00		XXX ± 0.00	
		A103:		XXX ± 0.00		XXX ± 0.00	
		A104:		XXX ± 0.00		XXX ± 0.00	
		A105:		XXX ± 0.00		XXX ± 0.00	
		A106:		XXX ± 0.00		XXX ± 0.00	
		A107:		XXX ± 0.00		XXX ± 0.00	
		A108:		XXX ± 0.00		XXX ± 0.00	
		A109:		XXX ± 0.00		XXX ± 0.00	
		A110:		XXX ± 0.00		XXX ± 0.00	
		A111:		XXX ± 0.00		XXX ± 0.00	
		A112:		XXX ± 0.00		XXX ± 0.00	
		A113:		XXX ± 0.00		XXX ± 0.00	
		A114:		XXX ± 0.00		XXX ± 0.00	
		A115:		XXX ± 0.00		XXX ± 0.00	
		A116:		XXX ± 0.00		XXX ± 0.00	
		A117:		XXX ± 0.00		XXX ± 0.00	
		A118:		XXX ± 0.00		XXX ± 0.00	
		A119:		XXX ± 0.00		XXX ± 0.00	
		A120:		XXX ± 0.00		XXX ± 0.00	
		A121:		XXX ± 0.00		XXX ± 0.00	
		A122:		XXX ± 0.00		XXX ± 0.00	
		A123:		XXX ± 0.00		XXX ± 0.00	
		A124:		XXX ± 0.00		XXX ± 0.00	
		A125:		XXX ± 0.00		XXX ± 0.00	
		A126:		XXX ± 0.00		XXX ± 0.00	
		A127:		XXX ± 0.00		XXX ± 0.00	
		A128:		XXX ± 0.00		XXX ± 0.00	
		A129:		XXX ± 0.00		XXX ± 0.00	
		A130:		XXX ± 0.00		XXX ± 0.00	
		A131:		XXX ± 0.00		XXX ± 0.00	
		A132:		XXX ± 0.00		XXX ± 0.00	
		A133:		XXX ± 0.00		XXX ± 0.00	
		A134:		XXX ± 0.00		XXX ± 0.00	
		A135:		XXX ± 0.00		XXX ± 0.00	
		A136:		XXX ± 0.00		XXX ± 0.00	
		A137:		XXX ± 0.00		XXX ± 0.00	
		A138:		XXX ± 0.00		XXX ± 0.00	
		A139:		XXX ± 0.00		XXX ± 0.00	
		A140:		XXX ± 0.00		XXX ± 0.00	
		A141:		XXX ± 0.00		XXX ± 0.00	
		A142:		XXX ± 0.00		XXX ± 0.00	
		A143:		XXX ± 0.00		XXX ± 0.00	
		A144:		XXX ± 0.00		XXX ± 0.00	
		A145:		XXX ± 0.00		XXX ± 0.00	
		A146:		XXX ± 0.00		XXX ± 0.00	
		A147:		XXX ± 0.00		XXX ± 0.00	
		A148:		XXX ± 0.00		XXX ± 0.00	
		A149:		XXX ± 0.00		XXX ± 0.00	
		A150:		XXX ± 0.00		XXX ± 0.00	
		A151:		XXX ± 0.00		XXX ± 0.00	
		A152:		XXX ± 0.00		XXX ± 0.00	
		A153:		XXX ± 0.00		XXX ± 0.00	
		A154:		XXX ± 0.00		XXX ± 0.00	
		A155:		XXX ± 0.00		XXX ± 0.00	
		A156:		XXX ± 0.00		XXX ± 0.00	
		A157:		XXX ± 0.00		XXX ± 0.00	
		A158:		XXX ± 0.00		XXX ± 0.00	
		A159:		XXX ± 0.00		XXX ± 0.00	
		A160:		XXX ± 0.00		XXX ± 0.00	
		A161:		XXX ± 0.00		XXX ± 0.00	
		A162:		XXX ± 0.00		XXX ± 0.00	
		A163:		XXX ± 0.00		XXX ± 0.00	
		A164:		XXX ± 0.00		XXX ± 0.00	
		A165:		XXX ± 0.00		XXX ± 0.00	
		A166:		XXX ± 0.00		XXX ± 0.00	
		A167:		XXX ± 0.00		XXX ± 0.00	
		A168:		XXX ± 0.00		XXX ± 0.00	
		A169:		XXX ± 0.00		XXX ± 0.00	
		A170:		XXX ± 0.00		XXX ± 0.00	
		A171:		XXX ± 0.00		XXX ± 0.00	
		A172:		XXX ± 0.00		XXX ± 0.00	
		A173:		XXX ± 0.00		XXX ± 0.00	
		A174:		XXX ± 0.00		XXX ± 0.00	
		A175:		XXX ± 0.00		XXX ± 0.00	
		A176:		XXX ± 0.00		XXX ± 0.00	
		A177:		XXX ± 0.00		XXX ± 0.00	
		A178:		XXX ± 0.00		XXX ± 0.00	
		A179:		XXX ± 0.00		XXX ± 0.00	
		A180:		XXX ± 0.00		XXX ± 0.00	
		A181:		XXX ± 0.00		XXX ± 0.00	
		A182:		XXX ± 0.00		XXX ± 0.00	
		A183:		XXX ± 0.00		XXX ± 0.00	
		A184:		XXX ± 0.00		XXX ± 0.00	
		A185:		XXX ± 0.00		XXX ± 0.00	
		A186:		XXX ± 0.00		XXX ± 0.00	
		A187:		XXX ± 0.00		XXX ± 0.00	
		A188:		XXX ± 0.00		XXX ± 0.00	
		A189:		XXX ± 0.00		XXX ± 0.00	
		A190:		XXX ± 0.00		XXX ± 0.00	
		A191:		XXX ± 0.00		XXX ± 0.00	
		A192:		XXX ± 0.00		XXX ± 0.00	
		A193:		XXX ± 0.00		XXX ± 0.00	
		A194:		XXX ± 0.00		XXX ± 0.00	

## ENVIRONMENTAL INFORMATION



This electronic equipment was manufactured according to high quality standards to ensure safe and reliable operation when used as intended. Due to its nature, this equipment may contain small quantities of substances known to be hazardous to the environment or to human health if released into the environment. For this reason, Waste Electrical and Electronic Equipment (commonly known as WEEE) should never be disposed of in the public waste stream. The “Crossed-Out Waste Bin” label affixed to this product is a reminder to dispose of this product in accordance with local WEEE regulations. If you have questions about the disposal process, please contact Metrix Customer Services.

[info@metrixvibration.com](mailto:info@metrixvibration.com)

[www.metrixvibration.com](http://www.metrixvibration.com)

8824 Fallbrook Dr. Houston, TX 77064, USA

Tel: 1.281.940.1802 • Fax: 1.713.559.9421

After Hours (CST) Technical Assistance: 1.713.452.9703